

Serie Light

SR325 Nylon Cable Chain

Inner height (D) 25,5 mm

Construction by single link.
Used with a special guide channel, is particularly suitable to long travel distance applications.
Movable separators can be installed to create different compartments.

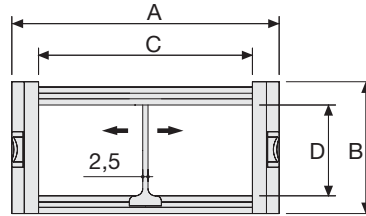

Separator

- Unassembled Part. no S325.1
- Assembled Part. no S325.1MC

Technical characteristics when self-supported

Speed	10 m/s
Acceleration	50 m/s ²

Technical characteristics when used in long travel distance

Speed	0,5 m/s
Acceleration	1 m/s ²

For higher requirements please consult our technical dept.

A	B	C	D	R	Weight/m	Chain
mm	mm	mm	mm	mm	kg	Part Number
55	37	40	25,5	050-060-075-100-125-150	0,83	SR325040 □□□*
75	37	60	25,5	050-060-075-100-125-150	0,95	SR325060 □□□*
91	37	76	25,5	050-060-075-100-125-150	1,06	SR325076 □□□*
118	37	103	25,5	050-060-075-100-125-150	1,12	SR325103 □□□*

*Complete the code by inserting the value of the radius (R): Ex. SR325040 □□□□

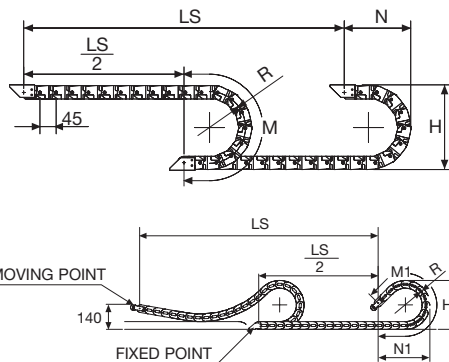

R	H	N	M	N1	M1
mm	mm	mm	mm	mm	mm
050	137	115	250	160	340
060	157	125	280	170	370
075	187	140	325	180	410
100	237	165	405	220	630
125	287	190	485	310	850
150	337	215	565	390	1070

Length of chain (L)
Half travel distance ($\frac{LS}{2}$)
plus length of curve (M) or (M1)

$$L = \frac{LS}{2} + M \text{ or } M1$$



Self-Supporting Capacity Diagram

The maximum length of the self-supporting capacity ($\frac{LS}{2}$) in relationship to the weight of the cables and hoses contained per linear metre.

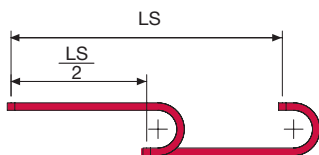
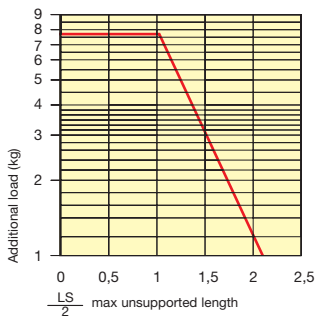

For applications with $\frac{LS}{2}$ and weights not included in the area of the diagram showing self-supporting capacity, verify the possible use of support rollers (see page 30).

Bright Zinc Plated Steel End Brackets*

The end brackets set allows the two ends of the chain to be attached to the equipment.

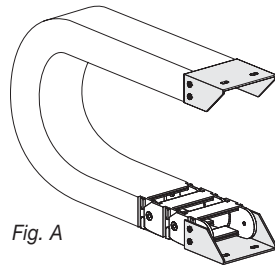
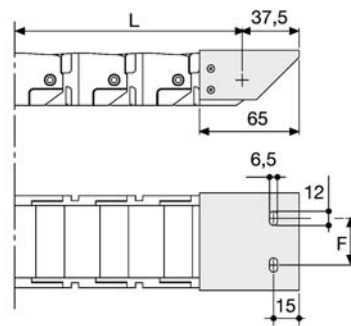

Fig. A

Chain fixed outside the radius. (Fig. A)
See end brackets mounting variations: page 31.



Chain	F
	mm
SR325040	24
SR325060	44
SR325076	60
SR325103	87

Bright Zinc Plated Steel End Brackets Part Numbers

Complete Set Assembled

Chain Type	End Brackets Set
SR325040	A325040KM <input type="checkbox"/> **
SR325060	A325060KM <input type="checkbox"/> **
SR325076	A325076KM <input type="checkbox"/> **
SR325103	A325103KM <input type="checkbox"/> **

Complete Set Unassembled

Chain Type	End Brackets Set
SR325040	A325040K <input type="checkbox"/> **
SR325060	A325060K <input type="checkbox"/> **
SR325076	A325076K <input type="checkbox"/> **
SR325103	A325103K <input type="checkbox"/> **

* Available on request in stainless steel

** 1=pos. 1; 2=pos.2; 3=pos.3

See end brackets mounting variations page 31.

Serie Light

SR325

Nylon Cable Chain

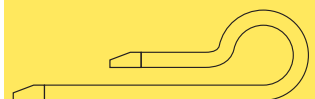

Suitable to long travel distance.
To choose the guide channel see page 52.

For further information please consult Brevetti Stendalto's Technical Office